

**BLACK POWDER
MUZZLELOADING
REVOLVERS AND CARBINES**

prod@arpiest@fhn.it

ed. 07/2006

Made in Italy by:



F.LLI PIETTA

F.A.P. Fabbrica Armi F.LLI PIETTA
di Pietta Giuseppe & C. snc

Via Mandolossa, 102
25064 GUSSAGO (Brescia) Italy
Cod. fisc.- P. iva IT00274400175
Tel. 39 030 37 37 098
Fax 39 030 37 37 100

www.pietta.it
e-mail: info@pietta.it



F.LLI PIETTA

HISTORICAL WEAPONS
REPRODUCTION

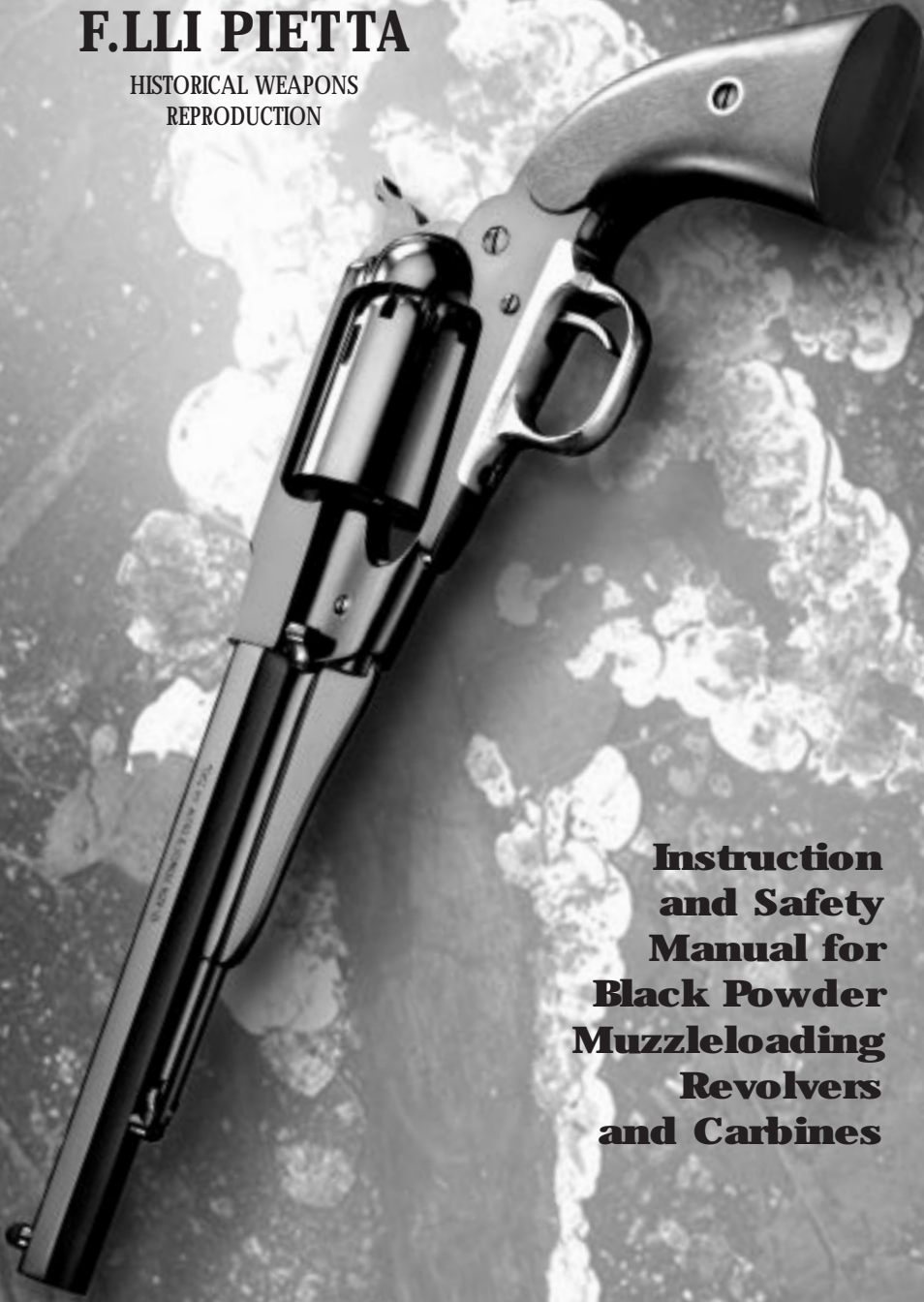

**Instruction
and Safety
Manual for
Black Powder
Muzzleloading
Revolvers
and Carbines**



READ THE INSTRUCTIONS AND WARNINGS IN THIS MANUAL CAREFULLY AND THOROUGHLY BEFORE HANDLING, LOADING OR SHOOTING THIS FIREARM !!



ENGLISH

BLACK POWDER MUZZLELOADING REVOLVERS AND CARBINES

INDEX	
THIS MANUAL CONTAINS	4
SAFETY PRECAUTIONS & WARNINGS	6
SAFETY PROCEDURES	11
LOADING	16
HANDLING	26
DECOCKING (UNCOCKING)	27
CARE AND CLEANING	29
STORAGE	32
LEAD EXPOSURE	33
STATE WARNINGS	34
NOMENCLATURES	37

THIS MANUAL CONTAINS:

- ▶ Important warnings which should be read and understood before using this firearm.
- ▶ Directions and procedures for handling, loading, firing and unloading.
- ▶ Instructions for care and cleaning.
- ▶ This instruction and safety manual is designed to help you in learning how to properly use and care for your **Elli Pietta** firearm. Only when you are certain you have fully familiarized yourself with the function of your firearm should you practice loading, unloading and firing.

This instruction manual should always accompany this firearm, and be transferred with it upon change of ownership.



WARNING: DISCLAIMER OF LIABILITY

ELLI PIETTA SHALL NOT BE RESPONSIBLE FOR PRODUCT MALFUNCTIONING OR FOR PHYSICAL INJURY, DEATH OR DAMAGE TO PROPERTY RESULTING FROM EITHER INTENTIONAL OR ACCIDENTAL DISCHARGE OF THIS FIREARM, ITS CRIMINAL OR NEGLIGENT USE, IMPROPER OR CARELESS HANDLING, UNAUTHORIZED MODIFICATIONS OR ALTERATION, USE OF DEFECTIVE OR IMPROPER CHARGES, OR FROM ITS USE FOR PURPOSES OR SUBJECTION TO TREATMENT FOR WHICH IT WAS NOT DESIGNED.



CAUTION:

PRIOR TO REMOVING THIS GUN FROM ITS PACKAGING, AND PRIOR TO LOADING AND FIRING, CAREFULLY AND THOROUGHLY READ THE ENTIRE INSTRUCTION MANUAL WHICH GIVES ADVICE ON THE GUN'S PROPER HANDLING AND FUNCTIONING. HOWEVER YOUR SAFETY AND THAT OF OTHERS (INCLUDING YOUR FAMILY) DEPENDS ON YOUR RESPONSIBLE COMPLIANCE WITH THAT ADVICE. IF UNFAMILIAR WITH FIREARMS, SEEK SUPERVISED INSTRUCTIONS. FIREARMS SAFETY IS YOUR RESPONSIBILITY.



WARNING: A FULLY LOADED UNCOCKED GUN, CAN FIRE!

WHEN THE HAMMER IS UNCOCKED, IT IS RESTING DIRECTLY ON A PERCUSSION CAP WHEN FULLY LOADED. A BLOW TO THE HAMMER RESULTING FROM A FALL/DROPPING OF THE GUN CAN CAUSE THE GUN TO DISCHARGE. TO PREVENT ACCIDENTAL DISCHARGES CAUSED BY A BLOW TO THE HAMMER: **ALWAYS** CARRY ALL REVOLVERS WITH THE HAMMER DOWN ON AN EMPTY CHAMBER, **ALWAYS** CARRY ALL MUZZLELOADING SIDE BY SIDE SHOTGUNS OR BREECHLOADING PERCUSSION CARBINES WITH THE HAMMER AT HALF COCK POSITION AND UNPRIMED.



IMPORTANT

TO ENSURE THE SHOOTER A BETTER PROTECTION, ALL THE MUZZLELOADING PERCUSSION FIREARMS MARKED **ELLI PIETTA** ARE SUBMITTED TO SEVERE FIRE TESTS EVIDENCED BY RELEVANT MARKINGS, MADE BY THE ITALIAN NATIONAL PROOF HOUSE OF GARDONE V.T. - BRESCIA - ITALY.



WARNING - LEAD EXPOSURE

DISCHARGING FIREARMS IN POORLY VENTILATED AREAS, CLEANING FIREARMS, OR HANDLING AMMUNITION MAY RESULT IN EXPOSURE TO LEAD AND OTHER SUBSTANCES KNOWN TO THE STATE OF CALIFORNIA (USA) TO CAUSE BIRTH DEFECTS, REPRODUCTIVE HARM AND OTHER SERIOUS PHYSICAL INJURY. HAVE ADEQUATE VENTILATION AT ALL TIMES. WASH HANDS THOROUGHLY AFTER EXPOSURE. SHOOTING OR CLEANING GUNS MAY EXPOSE YOU TO LEAD.

Safety Precautions & Warnings



Warning:

CARELESS AND IMPROPER HANDLING OF THIS GUN COULD RESULT IN AN UNINTENTIONAL DISCHARGE CAUSING INJURY, DEATH OR PROPERTY DAMAGE!

1 Careless and improper handling of this gun could result in unintended discharge causing injury, death or property damage. Safety must be the first and constant consideration when handling a firearm and ammunition. **Elli Pietta snc** shall not be responsible for product malfunctioning or for physical injury, death or damage to property resulting from either intentional or accidental discharge of this firearm, its criminal or negligent use, improper or careless handling, or from its use for purposes or subsection to treatment for which it was not designed.

2 **NEVER** alter any part or add or replace parts not supplied by Elli Pietta s.n.c. This product was designed to function properly in its original condition.

Elli Pietta snc shall not be responsible for product malfunctioning or for physical injury, death or damage to property resulting from unauthorized modifications or alterations.

3 **ALWAYS** carry revolvers with the hammer down on an **empty** chamber to prevent accidental discharges caused by a blow to the hammer or with the hammer set on the proper safety position (Read carefully the instructions paragraph about the various type of revolvers). **ALWAYS** carry muzzleloading side by side shotgun, muzzleloading or breechloading percussion carbine with the hammer at half cock position (or charging cock position) and **unprimed (without percussion cap in place)**.

4 **ALWAYS** handle and treat your gun as if it were loaded so you never fire it accidentally when you think it is unloaded. **NEVER** think it is unloaded. **NEVER** take anyone's word it is unloaded. **ALWAYS** check it yourself with your fingers off the trigger and the gun pointed in a safe direction at all times, including while loading. **NEVER** lean over the muzzle. **ALWAYS** make capping the nipples the last step of loading.

5 **NEVER keep or carry any firearm with the hammer cocked.** Cocking the gun or pulling the trigger should only be done when you are ready to shoot immediately. This way, your gun cannot be unintentionally fired.

6 **ALWAYS** leave your fingers out of the trigger until you start firing. **Note: safety devices on guns are extras and do not substitute for safe handling.**

7 **NEVER** perch the gun on the half-cock notch as it may fall and discharge, causing damage to property, injury or death. The half-cock position provides only partial security from accidental discharges. If damaged or modified it provides **NO** Safety. **NEVER** depend on this device to prevent accidental discharge !

8 **ALWAYS keep the muzzle pointed in a safe direction.** This way, if it fires accidentally, personal injury, death or damage to property can be prevented. This is especially important when loading and unloading your gun.

NEVER let the muzzle of the firearm point at any part of your body or at another person or at anything you do not intend to shoot, even if you think it is unloaded. **ALWAYS** be certain of your target before firing.

9 **ALWAYS unload all firearms when not in use. NEVER** store or transport a loaded firearm. Firearms and ammunition should be safely stored separately in locked receptacles minimizing the risk that the gun and ammunition could be easily available for loading and firing.

10 **ALWAYS store your firearms out of sight and reach of children or visitors.**

11 **ALWAYS make sure your gun is not loaded before cleaning, storing or travelling or before laying it down, or handing it to another person for use.**

12 **NEVER climb a tree, fence or wall while carrying a loaded firearm. NEVER** leave a loaded gun unattended or resting against a tree, fence or wall. Someone, especially a child, may fire it and cause injury, death or damage to property.

13 **NEVER shoot at a hard surface or at water.** A bullet may ricochet and travel in unpredictable directions to strike you or an object you cannot see, causing injury, death or damage to property.

14 **NEVER** fire your gun near an animal as the animal's startled reaction could result in injury or accidents.

15 **Firearms and alcohol don't mix. NEVER drink alcoholic beverage or take drugs before or during shooting sessions**, as this constitutes criminal disregard for your safety and that of others. **NEVER** use a gun while you are taking medication unless you have checked with your doctor to ensure your fitness to handle your gun safely.

16 Be particularly careful when unloading the revolver to check the cylinder to be certain a live round does not remain in it.

17 Before loading the gun make sure it is not **ALREADY** loaded.

18 **DO NOT** use burning patches.

19 **DO NOT** fire the gun when unloaded as it could result in damages to the nipples, causing bulge and preventing the caps to properly lodge.

20 Use soft lead ball only. Other materials or alloys will not travel freely through the barrel.

21 **NEVER** smoke while loading, shooting or handling black powder propellant.

22 **NEVER** charge a muzzleloader directly from the powder flask. Use individual charges from a powder measure when loading your gun.

23 **ALWAYS** be certain that the ball is seated firmly against the powder charge before firing any muzzleloading firearm. Any gap between the ball and the powder charge could cause excessive pressure and explosion of the barrel. If you can't push the ball against the powder charge, use a ball puller to remove it. Never remove the nipple when the gun is loaded.

24 Keep all persons nearby to the rear of the shooter. Standing beside or in front of the shooter is not safe. Flames, hot gases and percussion cap fragments might fly from the side of the gun causing serious injury.

25 Treat a misfire or failure to fire with extreme care. Keep gun pointed in a safe direction downrange and wait at least one full minute before attempting to reprime it. There is always a chance a spark is smoldering in the powder charge and the gun could fire at any second.

26 Store black powder and percussion caps in separate locations and use original containers when possible.

27

Black powder deposits heavy residues on all metal parts and eventually it could jeopardize the good functioning of the gun. If black powder deposits on the cock position notch it could undo the proper functioning of the cock position. Thorough cleaning is necessary after each shooting session. Use a good black powder solvent or plenty of hot water. When the gun is cleaned and dry, apply a light rust preventative gun oil to all metal parts.

28

While on the firing line, keep all black powder canisters closed.

29

If you have any doubts about your ability to handle or use this gun safely DO NOT handle or use this gun. You must seek supervised instruction before doing so.

30

Horseplay has no place around firearms. Guns can't think, you can.

31

REMEMBER, SAFETY IS YOUR RESPONSIBILITY. BE A SAFE SHOOTER AND USE COMMON SENSE AT ALL TIMES.



WARNING:

DEATH, SERIOUS INJURY, AND PROPERTY DAMAGE CAN RESULT FROM THE USE OF WRONG AMMUNITION, BORE OBSTRUCTIONS, POWDER OVERLOADS, OR INCORRECT COMPONENTS!

32

Death, serious injury and damages can result from the use of wrong powder or wrong caliber ammunition. **For your safety and for all bystanders, all muzzleloading firearms are intended for use with BLACK POWDER ONLY.**

Use of any other propellant will result in serious injury to the shooter and damage to the firearm. Never under any circumstances attempt to use smokeless powder or a mixture of black powder and smokeless powder. Do not overcharge. Follow the recommended load data charts in this instruction manual and do not exceed the maximum charges.

Elli Pietta snc shall not be responsible for physical injury, death or damage to property resulting from the use of improper propellant.

33

Water, snow, mud, excess of lubricant oil or grease or any other material can obstruct the barrel of your gun and cause injury or fatality. **ALWAYS** check the barrel of your firearm for obstruction before loading and firing. If you observe any obstruction, **IMMEDIATELY** clean the gun to ensure your gun will function correctly and safely.



WARNING:

FAILURE TO WEAR EYE PROTECTION CAN RESULT IN EYE INJURY!

34

ALWAYS wear safety glasses while shooting to protect your eyes from injury by gun powder, hot gases, lubricant, dirt or metallic particles, carbon residue, sparks or other debris.

Omit wearing safety glasses can cause injury to your eyes. **ALWAYS** wear safety glasses when disassembling and cleaning any gun to prevent the possibility of springs, spring tension parts, solvents, or other agents from entering and irritating your eyes.



WARNING:

EXPOSURE TO SHOOTING NOISE CAN RESULT IN PERMANENT HEARING LOSS!

35

ALWAYS use the due cautions. ALWAYS wear and encourage others near you to wear ear protection when shooting, especially on a range. Without ear protection, the noise from your gun, and other guns close to you, could leave a "ringing" in the ears for some time after firing. Repeated exposure to shooting noise could result in permanent hearing loss.

SAFETY PROCEDURES

ALWAYS handle and carry revolvers with the hammer down on an **empty** chamber to prevent accidental discharges caused by a blow to the hammer or with the hammer positioned on the proper safety position. This paragraph will explain the various safety devices and safety positions designed at that time for every single gun. Always remember that these systems cannot be considered effective because they are not easy positions to find on the guns. The safest way is to always carry unloaded guns.

1851 NAVY MODEL

There are 6 pins (part # 73) on the cylinder and there is a slit on the hammer (part # 18) where it hits the percussion cap. To put this revolver on a safety condition one of the 6 pins must be inserted into the hammer slit. Slightly pull the hammer backward so that the cylinder is free to rotate. When the pin is lined up with the hammer slit release hammer downward the cylinder. With a hand slightly rotate the cylinder right or left until the pin gets into the hammer slit (picture 1). This way the cylinder is locked.

BE VERY CAREFUL, THIS IS A DANGEROUS AND DELICATE STEP. ALWAYS REMEMBER YOUR GUN IS LOADED.

To release the safety position cock the hammer and the gun is ready to fire.

1860-1861-1862 ARMY MODELS

There are 6 pins (part # 14) on the cylinder and there is a slit on the hammer (part # 18) where it hits the percussion cap. To put this revolver on a safety condition one of the 6 pins must be inserted into the hammer slit. Slightly pull the hammer backward so that the cylinder is free to rotate. When the pin is lined up with the hammer slit release hammer downward the cylinder. With a hand slightly rotate the cylinder right or left until the pin gets into the hammer slit (picture 1). This way the cylinder is locked.

BE VERY CAREFUL, THIS IS A DANGEROUS AND DELICATE STEP. ALWAYS REMEMBER YOUR GUN IS LOADED. To release the safety position cock the hammer and the gun is ready to fire.

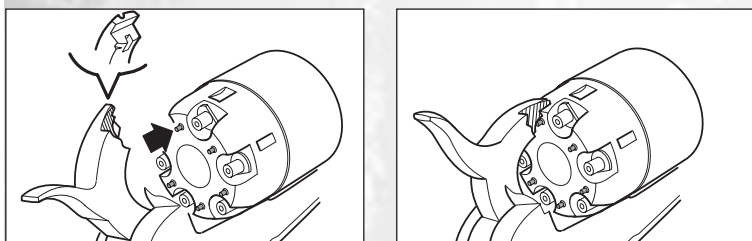

FIG. 1

1858 NEW MODEL ARMY/NAVY

There are 6 slits on the cylinder and to put this revolver on a safety condition you must insert the hammer head in one of the cylinder slits. Slightly pull the hammer backward so that the cylinder is free to rotate. When the cylinder slit is lined up with the hammer head lower the hammer to the cylinder. With a hand gently rotate the cylinder right or left so that the hammer head gets into the cylinder slit (picture 2) This way the cylinder is locked.

BE VERY CAREFUL, THIS IS A DANGEROUS AND DELICATE STEP. ALWAYS REMEMBER YOUR GUN IS LOADED.

To release the safety position cock the hammer and the gun is ready to fire.

1862 SPILLER & BURR MODEL 1863 NEW MODEL POCKET

There are 5 slits on the cylinder and to put this revolver on a safety condition you must insert the hammer head in one of the cylinder slits. Slightly pull the hammer backward so that the cylinder is free to rotate. When the cylinder slit is lined up with the hammer head lower the hammer to the cylinder. With a hand gently rotate the cylinder right or left so that the hammer head gets into the cylinder slit (picture 2). This way the cylinder is locked.

BE VERY CAREFUL, THIS IS A DANGEROUS AND DELICATE STEP. ALWAYS REMEMBER YOUR GUN IS LOADED.

To release the safety position cock the hammer and the gun is ready to fire.

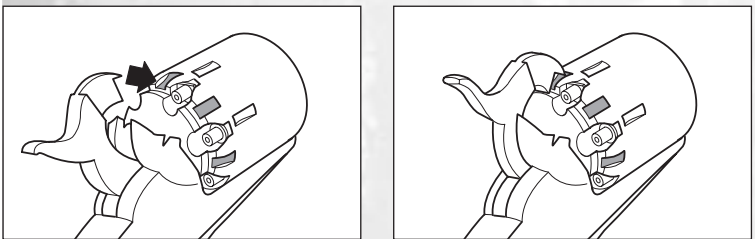

FIG. 2

1873 S.A. PERCUSSION REVOLVER

There are 6 slits on the cylinder and to put this revolver on a safety condition you must insert the firing pin (part # 24) in one of the cylinder slits. Slightly pull the hammer backward so that the cylinder is free to rotate. When the cylinder slit is lined up with the firing pin lower the hammer to the cylinder. With a hand gently rotate the cylinder right or left so that the firing pin gets into the cylinder slit (picture 3). This way the cylinder is locked. **BE VERY CAREFUL, THIS IS A DANGEROUS AND DELICATE STEP. ALWAYS REMEMBER YOUR GUN IS LOADED.** To release the safety position cock the hammer and the gun is ready to fire.

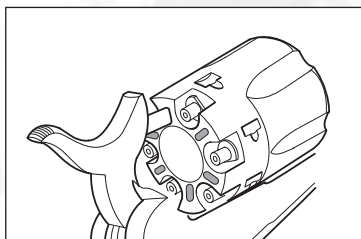
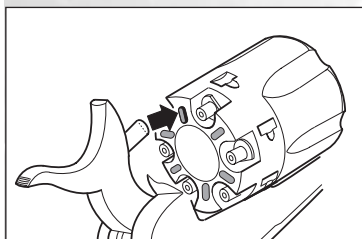

FIG. 3

1858 STARR D.A. MODEL

There are 12 slits on the cylinder, 6 of which keep the cylinder in firing position and 6 in safety position. To put this revolver on a safety condition you must insert the main trigger (part # 21) in one of the cylinder slits. Slightly pull the hammer backward so that the cylinder is free to rotate. When the cylinder slit is lined up with the main trigger lower the hammer to the cylinder. With a hand gently rotate the cylinder right or left so that the main trigger gets into the cylinder slit (picture 4). This way the cylinder is locked. **BE VERY CAREFUL, THIS IS A DANGEROUS AND DELICATE STEP. ALWAYS REMEMBER YOUR GUN IS LOADED.** To release the safety position cock the hammer and the gun is ready to fire.

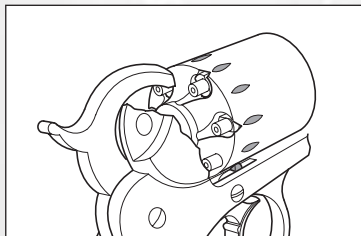
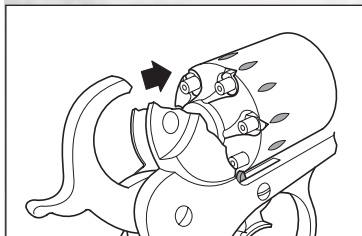

FIG. 4

1863 STARR S.A. MODEL

There are 12 slits on the cylinder, 6 of which keep the cylinder in firing position and 6 in safety position. To put this revolver on a safety condition you must insert the bolt (part # 43) in one of the cylinder slits. Slightly pull the hammer backward so that the cylinder is free to rotate. When the cylinder slit is lined up with the bolt lower the hammer to the cylinder. With a hand gently rotate the cylinder right or left so that the bolt gets into the cylinder slit (picture 5). This way the cylinder is locked.

BE VERY CAREFUL, THIS IS A DANGEROUS AND DELICATE STEP. ALWAYS REMEMBER YOUR GUN IS LOADED.

To release the safety position cock the hammer and the gun is ready to fire.

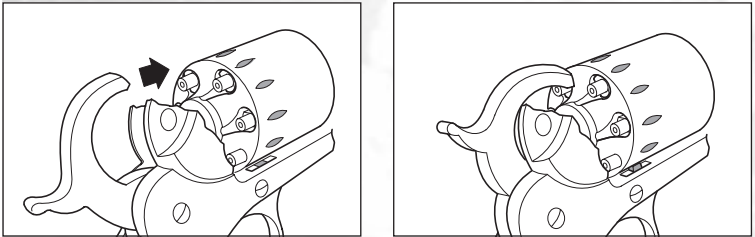

FIG. 5

PATERSON MODEL

For this model there are no safety devices or safety positions. **ALWAYS** carry this gun unloaded.

LEMAT MODEL

For this model there are no safety devices or safety positions. **ALWAYS** carry this gun unloaded.

SMITH CARBINE

For this model there are no safety devices or safety positions. **ALWAYS** carry this gun unloaded.

ALWAYS handle and carry revolvers with the hammer down on an **empty** chamber to prevent accidental discharges caused by a blow to the hammer or with the hammer positioned on the proper safety position. This paragraph will explain the various safety devices and safety positions designed at that time for every single gun. **Always remember that these systems cannot be considered effective because they are not easy positions to find on the guns. THE SAFEST WAY is to always carry unloaded guns.**

LOADING



WARNING:

BLACK POWDER IS EXPLOSIVE!

PLEASE REVIEW THE WARNINGS OF THIS MANUAL REGARDING BLACK POWDER.

BLACK POWDER CHOICE

Black Powder is extremely sensitive and is readily ignited by heat, spark, static electricity, friction, pressure, flame, etc.

- 1 ONLY** handle Black Powder in very small quantities.
- 2 DO NOT** overcharge.
- 3 ALWAYS** follow the recommended load data charts in this instruction manual.
- 4 NEVER** exceed the maximum charges specified in the manual.
- 5 DO NOT** use burning patches.
- 6 NEVER** smoke while loading, shooting or handling black powder.
- 7 NEVER** charge a muzzleloader directly from the powder flask.
- 8 ALWAYS** use individual charges from a powder measure when loading your gun.
- 9 BE CERTAIN** that the ball is seated firmly against the powder charge before firing any muzzleloading firearm. Any gap between the ball and the powder charge could cause excessive pressure and explosion of the barrel. If you can't push the ball against the powder charge, use a ball puller to remove it.
- 10 NEVER** remove the nipple when the gun is loaded.
- 11 ALWAYS** store black powder and percussion caps in separate locations and use original containers when possible.
- 12** While on the firing line, **ALWAYS** keep all black powder canisters well closed.
- 13 USE** soft lead ball **ONLY**. Other materials or alloys will not travel freely through the barrel.



WARNING:

NEVER LOAD YOUR GUN WITH ANY TYPE OF SMOKELESS POWDER OR OTHER PROPELLANT!

For your safety and for all bystanders, all muzzleloading firearms are intended for use with **BLACK POWDER ONLY**.

Use of smokeless powder or other unauthorized propellant could result in damage to the revolver and/or injury to the shooter or bystanders.

ALWAYS use **BLACKPOWDER ONLY**.

NEVER under any circumstances attempt to use smokeless powder or a mixture of black powder and smokeless powder.

E.lli Pietta s.n.c. shall not be responsible for physical injury, death or damage to property resulting from the use of improper propellant.

BLACK POWDER LOADING DATA

Make no mistake about it, black powder is the only propellant powder that is safe to use in a muzzleloading firearm. The reason for using black powder and black powder only is quite basic and it is related to firearms design. When used as a propellant, black powder generates a relatively low breech pressure. Replica firearms, even with their modern steel barrels, are not designed to withstand the high pressure produced by modern smokeless powder.

Black powder is available in different granulation sizes :

- 1f or Fg** – largest granulation type, to be used mainly with big caliber firearms
- 2f or FFg** – to be used with .50 cal. firearms and .10, .12, .16 and .20 ga. side by side
- 3f or FFFg** – standard granulosity, recommended for .31, .36 and .44 cal. revolvers
- 4f or FFFFg** – granulosity used for flintlock primers only

Keep black powder off heat sources.

Loading

RECOMMENDED BLACK POWDER LOADING DATA AND BALL DIAMETER

Use the following loading information to select the powder charge and the ball diameter:

CALIBER	BALL DIAMETER	BALL DIAMETER	BALL TYPE	FFG GRAINS MIN-MAX	FFG GRAMS MIN-MAX	FFG GRAINS MIN-MAX	FFG GRAMS MIN-MAX
.31 REVOLVER	.322"	8,20 mm	Round	–	–	7-9	0,5-0,6
.36 REVOLVER	.375"	9,55 mm	Round	–	–	9-12	0,6-0,8
.44 REVOLVER	.454"	11,55 mm	Round	–	–	12-15	0,8-1
.44 COMPEL. REV.	.464"	11,80 mm	Round	–	–	12-15	0,8-1
.20 ga REVOLVER	.27"	6,85 mm	Round	25-35	1,6-2,2	–	–
.50 SMITH	.510"	12,95 mm	Ogival	–	–	35-50	2,1-3,2
.20 SHOTGUN	Pellets no 8	–	Round	72	4,5	Pellets weight	32
.12 SHOTGUN	Pellets no 8	–	Round	60	3,9	Pellets weight	36



WARNING:

NEVER EXCEED THE MAXIMUM LOAD SPECIFIED IN THE LOAD DATA CHART ABOVE.

PERCUSSION CAPS

A Percussion cap is a small metal cap, which is coated with a priming mixture on the top of its interior. This priming mixture fires when it is struck.

To fully load the revolver, place a percussion cap on a cylinder nipple. When struck by the hammer, the percussion cap's priming mixture explodes, igniting the powder charge.

Try to keep water, grease, dirt, or other contaminants out of the open end of percussion caps. Failure to do so can cause misfires.



WARNING:

NEVER CARRY A CYLINDER THAT IS CAPPED!

A Capped Cylinder loaded with powder and ball is the equivalent of a small firearm. A capped cylinder can discharge if dropped or struck.

ONLY place a percussion cap on cylinder when you are ready to fire. Failure to do so can result in an accidental discharge causing injury, death or property damage.

NEVER carry the gun with the hammer resting on a percussion cap! A light accidental blow to the hammer can readily cause the gun to discharge.

LOADING MUZZLELOADING FIREARMS



WARNING:

FOR YOUR SAFETY AND FOR ALL BYSTANDERS ALWAYS USE BLACK POWDER ONLY !

If there is one rule that you must not break when loading black powder firearms, it is the following: **use black powder only.**

Do not be at all tempted to either load your weapon with smokeless powder of any sort, nor attempt to mix black powder and smokeless powder together.

- 1** Wipe away any grease and oil from the cylinder chambers, the inside of the barrel, the nipples and pockets around the nipples. Use a degreasant such as refined petroleum lighter fuel to rid the revolver of grease and oil before attempting to use the weapon.
- 2** Make sure each nipple is firmly seated.
- 3** Draw the hammer back until it clicks in the half-cock notch (loading cock position), thus allowing the cylinder to rotate freely.
- 4** Do not load the weapon with powder and ball yet but place a percussion cup on each nipple.
- 5** Fully cock the hammer and pointing the revolver downrange, pull the trigger to fire the cap to dry out the base of the chamber and nipple.
This will insure ignition and clear away any oil in the nipple port. Repeat this procedure for all nipples to insure that each chamber is thoroughly dry and clean. Check to be sure no unfired caps have been inadvertently left on the nipples. If so, fire them.
- 6** Place hammer at half cock position (loading cock position) and rotate cylinder to remove all spent caps. Hold the muzzle upward. Using a revolver powder measure, pour a measured charge into a chamber.
Rotate cylinder. Repeat procedure for the other chambers. Lay a pre-cut patch or a dose of semolina over the muzzle.
- 7** Place a properly sized ball or bullet of pure lead onto the opening of the chamber.

8

Rotate cylinder to place chamber in line with the loading lever plunger. Using the loading lever, apply smooth and uninterrupted pressure to seat ball into the chamber and firmly on top of the powder. The ball should lay .040" (1mm) below the cylinder edge. A thin ring of lead will be shaved off the ball at the opening of the chamber. This occurrence illustrates that the ball is properly fitted to the chamber and will not move off the powder during the firing of the other chambers. Do not crush the powder. Normally only five chambers of a six-shot gun or four of a five-shot gun or eight of a nine-shot gun are loaded. The gun is to be used and carried with the hammer resting on the uncapped nipple of the unloaded chamber. By doing so you reduce the possibility of accidental firing.

**WARNING:**

TO AVOID AN ACCIDENTAL DISCHARGE, ALWAYS LOAD ONLY :
FIVE CHAMBERS OF A SIX-SHOTS GUN
FOUR CHAMBERS OF A FIVE-SHOTS GUN
EIGHT CHAMBERS OF A NINE-SHOTS GUN

**WARNING:**

ALWAYS USE AND CARRY YOUR GUNS WITH THE HAMMER RESTING ON THE UNCAPPED (WITHOUT PERCUSSION CAP IN PLACE) NIPPLE OF THE UNLOADED CHAMBER !

9

Fill the remaining portion of each loaded chamber with grease. Suitable products are natural lube, water pump grease or vegetable fat like crisco. This not only helps form a gas seal when the ball enters the barrel, but also prevents chain firing of all chambers at once, and aids in cleaning.

10

With the gun pointed in a safe direction and hammer in half cock position, place the proper size percussion caps on the nipple of each loaded chamber.

11

ALWAYS place the hammer down on the empty safety chamber to prevent accidental discharge from inadvertent striking or dropping of the gun and consequent unintentional shot. The gun will now fire each time the hammer is full cocked and the trigger is pulled.

Your gun is now ready to fire.

ABOUT THE LE MAT REVOLVER

We recommend the following ball sizes for the two different calibers of this gun:

.44 cal.: .454" (mm 11,55) -(part no. 8)

.20 ga. : round grapeshot balls .27 cal. (mm 6,85) approx 3/4 ounce to 1 ounce - (part no. 14)

After loading the cylinder and the center barrel, NEVER place any cap on the nipple under the hammer, for the .20 ga. The cap could be misplaced (too high) causing a double percussion which would fire 2 shots simultaneously.



WARNING:

A CAP, IF PLACED ON THE NIPPLE UNDER THE HAMMER FOR THE .20 GA. COULD BE MISPLACED, CAUSING A MISFIRE THAT CAN RESULT IN PERSONAL INJURY, DEATH OR PROPERTY DAMAGE: NEVER PLACE A PERCUSSION CAP ON THE NIPPLE UNDER THE HAMMER FOR THE .20 GA.

ABOUT THE 1873 S.A. MUZZLE LOADING PERCUSSION REVOLVER .44 CAL.

This is the black powder percussion version of the 1873 S.A. cartridge revolver and therefore does not feature a loading lever. For easy loading of the chambers, remove the cylinder as follows: open the loading gate located in the right side of the frame. Place the hammer in the second notch, the cylinder should be now free to rotate. Slide the base pin and rotate the cylinder clockwise toward the loading gate. Use the proper loading stand (our Item. No. AC565). Follow then the same loading instructions as for all others muzzleloading black powder revolvers.

ABOUT THE SMITH CARBINE

This hinged frame carbine is considered a blackpowder breech loading firearm. It requires therefore the same precautions as with the blackpowder muzzleloading revolvers. The Smith carbine cannot be loaded directly from the muzzle like other muzzleloading rifles but requires brass re-usable cartridge case (our item AC460 of our catalog) which must be loaded following the same procedure used for loading the chambers of the revolvers' cylinder. Press upwards on the "T" shaped bar inside the trigger guard (part no. 32) to allow the barrel to swing down for loading. The barrel is chambered to lodge the cartridge case.

Insert the cartridge case and fold up the gun. Place a cap on the nipple. After shooting, open the frame and remove the cartridge case. To clean the barrel, open the frame and use a wood, aluminum or brass cleaning rod and a swab.



WARNING:

DO NOT PLACE THE CAP ON THE NIPPLE UNTIL YOU ARE READY TO SHOOT

ABOUT THE MUZZLELOADING SHOTGUN

Stand with the rifle on its butt with the barrel pointing to a safe position and away from your face and body. Make sure the hammers are at a rest position (loading position) and that the nipples are uncapped. Measure and pour the powder down the right hand barrel first, using an adjustable measure or pre-weighed charges. Strike the barrel several sharp raps with the heel of your hand; this will settle the powder into the barrel chamber. Place on the muzzle an over-the-powder wad (preferably of cork). Remove the ramrod from the thimbles and place the head over the wad. Carefully press the wad past the muzzle and ram it smoothly down to a firm seat on top of the powder charge. Mark your ramrod at the top of the barrel so that in future loadings it can be used as a gauge to easily determine that you have used the proper load and it is seated correctly. Measure and pour the desired weight and size of shots down the barrel. The over-shot card wad is the last major operation. Push one corner of the wad down past the muzzle and collapse the rim of the wad slightly. Place the head of the ramrod over the card wad and press it smoothly down the bore until it lodges solidly on top of the shots charge. It is a wise practice to mark your ramrod on the muzzle. A reference mark on the ramrod will insure that all future shots are seated to the same depth. Start now loading the left hand barrel. Finally, place the caps on the nipples and your gun is now ready to shoot.

ABOUT THE 1858 STARR DOUBLE ACTION REVOLVER



WARNING:

NEVER MANUALLY COCK THIS GUN, READ THE FOLLOWING INSTRUCTIONS FIRST.

The 1858 Starr Revolver is unlike that of any Black Powder Revolver made. Please read and understand the functions, features and operation before handling, loading or shooting this firearms.

MAIN FEATURES OF THE 1858 STARR D.A.

- 1** Take down bolt – This is a knurled bolt located on the right side of the frame. Unscrew and remove the bolt to allow a quick and easy removal of the cylinder.
- 2** Trigger switch – This switch, located on the back of the main trigger, is used to change from “double action” mode to “single action” mode. Switch up: Double Action Firing – Switch down: Single Action Firing.
- 3** Secondary Trigger – Located on the rear of the trigger guard. This trigger will fire the gun when in the “Single Action” mode.

DOUBLE ACTION MODE

When The Starr revolver is used in the “double action” mode, the main trigger will be performing all of the functions and the gun will fire by simply pulling the trigger fully to the rear.

SINGLE ACTION MODE

If you pull the main trigger in the “single action” mode, the hammer will cock back and the cylinder will rotate to the chamber to be fired but unlike the double action trigger mode, the hammer will not fall. To fire the gun, pull the secondary trigger.



WARNING:

IN THE “SINGLE ACTION” MODE THE MAIN TRIGGER IS USED TO COCK THE HAMMER. TO ACTUALLY FIRE THE GUN, THE SECONDARY TRIGGER HAS TO BE PULLED.
THE STARR REVOLVER IS UNABLE TO BE MANUALLY COCKED BY THE HAMMER.

HALF COCK POSITION

Draw the hammer backward of about $\frac{1}{4}$ and you will feel the hammer “click” into its half cock position. This will allow the cylinder to rotate freely for easy loading and priming.

NOTE: When rotating the cylinder for loading or priming, to ensure that you do not scratch the cylinder, you will need to pull gently on the trigger to lower the cylinder stop bolt.

TROUBLE SHOOTING GUIDE

- ▶ Ball seated without powder: sooner or later this seems to happen to everyone. It may be necessary to take apart the cylinder and use a worm or similar device to remove the ball or unscrew the nipple and push out the ball.
- ▶ Ball non seated against the powder charge: if due to powder fouling or other circumstances, a ball becomes lodged part way down the barrel, then the revolver must be disassembled and the charge removed. A stuck ball cannot be fired out of the barrel safely because it will act as a bore obstruction and possibly damage the revolver or worse. Never fire a muzzleloading firearm unless the ball is seated against the powder charge.
- ▶ If the cap fired but the chamber did not, the nipple may be clogged.
- ▶ If the cap did not fire, either the hammer did not hit hard enough or the cap is defective. If the cap is not defective the cure is to cock the hammer and flick out the cap fragments from the previous shot which sometimes get caught under the hammer. To remove the fragments use a knife blade or a small screwdriver.

HANDLING

The term "Single Action" means that the hammer of your revolver must be manually drawn **fully** rearward, or cocked before firing each shot. In the process of cocking your revolver, you should note that there are two separate hammer positions, each one having its purpose.

1 LOADING AND UNLOADING POSITION

Draw the hammer backward and you will feel the hammer click into its first position (if you listen carefully, you can hear it). In this position the cylinder rotates freely clockwise. This permits you to load or unload your revolver.(fig.1).

2 FIRING (full cock) POSITION

Draw the hammer fully rearward to its full-cock notch. Make sure it clicks into this rearmost position. Your revolver is now ready to fire. (fig2).



FIG. 1

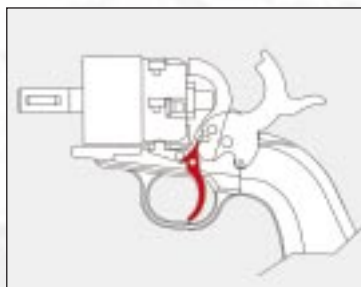

FIG. 2

CAUTION:

NEVER ATTEMPT TO FIRE YOUR REVOLVER IN ANY POSITION EXCEPT THE FULL-COCK POSITION. ATTEMPTING TO PULL THE TRIGGER IN THE HALF-COCK POSITION WILL STRAIN THE MECHANISM AND POSSIBLY MAKE IT UNSAFE. (IT MIGHT EVEN BREAK IF YOU ARE STRONG ENOUGH).



Decocking (Uncocking) the Revolver

If you have your revolver in the full-cock position and change your mind and don't want to shoot, carefully follow these steps:

- 1** Make certain that the revolver is pointing in a safe direction.
- 2** Make certain both hands are dry and not impeded in any way, gloves, bandages, cold, etc.
- 3** Fully draw the hammer back with your thumb and continue holding it fully rearward while pulling the trigger backward. Hold the trigger and hammer back in this position.
- 4** While holding the trigger back, slowly lower the hammer downward past its half cock notch (half-cock notch loading position) until it rests on the cap.
REMEMBER, YOU ARE LOWERING IT TOWARD A LIVE CHARGE!
Be careful and keep the firearm pointed in a safe position.
- 5** Pull the hammer back until it clicks on the half cock notch (half-cock notch loading position). The cylinder is now free to rotate.
- 6** Make the cylinder rotate until the empty and unprimed chamber is lined up with the hammer.
- 7** Slightly draw the hammer rearward and pull the trigger. When the hammer past its half-cock notch (half-cock notch loading position), lower it slowly down against frame.



FIG. A



FIG. B

Fig A - With the thumb controlling the hammer as shown above (1), squeeze the trigger to permit the hammer to break free (2)

Fig B - When hammer is free, immediately release trigger (3). Then lower the hammer slowly to its resting position completely down against frame.



Caution!!

YOU SHOULD PRACTICE THIS IMPORTANT GUN HANDLING SKILL WITH AN UNLOADED REVOLVER UNTIL YOU HAVE DEVELOPED THE PROPER CONTROL AND TOUCH TO DECOCK YOUR REVOLVER SAFELY.



Caution!!

USE EXTREME CARE WHEN ATTEMPTING TO DECOCK THE REVOLVER. AS THE THUMB SLIPPING DURING THIS PROCESS CAN RESULT IN AN ACCIDENTAL DISCHARGE IF THE TRIGGER IS HELD TO THE REAR.



Caution!!

REMEMBER, WHEN YOU FULLCOCK YOUR REVOLVER TO SHOOT IT AGAIN, YOU ROTATE THE CYLINDER. WHEN YOU DECOCK YOUR REVOLVER AND DECIDE NOT TO FIRE, THAT CHARGE IS STILL LIVE IN THE CYLINDER AND WILL ROTATE WITH EACH COCKING. **DO NOT FORGET ABOUT THIS CHARGE.** IF YOU FIRED PRIOR TO THE DECOCKING OPERATION AND START FIRING AGAIN, THE HAMMER WILL FALL ON ONE OR MORE EMPTY CHAMBERS AND STILL WILL FALL ON THE LIVE CHARGE.

BE EXTREMELY CAREFUL OF THIS LIVE CHARGE.

Care and Cleaning



Caution:

ALWAYS MAKE SURE THE REVOLVER IS COMPLETELY UNLOADED BEFORE CLEANING. WEAR SAFETY GLASSES IN CASE YOU LOSE CONTROL OF SOME SPRING-LOADED COMPONENT WHICH COULD INJURE YOUR EYES.



Caution:

YOUR MUZZLELOADING FIREARM MUST BE CLEANED AFTER EACH SHOOTING SESSION TO PREVENT RUST AND CORROSION FROM DAMAGING THE METAL PARTS.

INITIAL CLEANING PROCEDURE FOR OPEN TOP FRAME BLACKPOWDER REVOLVERS (COLT-STYLE REVOLVERS) - MAKE SURE YOUR GUN IS UNLOADED

1 Remove the wedge, located just forward of the cylinder by tapping it with a wooden or plastic wedge and a hammer through the slot in the side of the barrel.

Proceed in this way: place the hammer in loading/unloading position, place the barrel on a small rise, put the punch on the wedge body that is sticking out of the barrel from the opposite side to that one of the screw and using a hammer strike it until complete removal from its seat. The wedge has a conical shape and therefore it's well locked; use a certain strength to remove it.

2 After the wedge is removed, separate the barrel from the frame.

3 Place hammer in half-cock position (loading position) to free the cylinder from the bolt and remove the cylinder from the cylinder pin.

4 Carefully clean all the metal parts with a good quality black powder solvent or with plenty of hot water.

Dry all parts thoroughly and lubricate lightly with gun oil. Do not apply the oil heavily as this will contribute to additional fouling during shooting and require more cleaning between shots.

INITIAL CLEANING PROCEDURE FOR FULL FRAME BLACKPOWDER REVOLVERS (REMINGTON' AND SPILLER & BURR'-STYLE REVOLVERS) - MAKE SURE YOUR GUN IS UNLOADED

- 1** Place hammer in half cock position (loading position).
- 2** Move the loading lever to the down position. Make sure plunger does not enter a cylinder chamber.
- 3** Pull or tap out the cylinder pin located under the barrel as far as it will go and rotate clock-wise the cylinder out of the frame.
- 4** Remove the grips and the triggerguard and carefully clean the gun with a good quality blackpowder solvent or plenty of hot water. Dry all parts thoroughly and lubricate lightly with gun oil. Do not apply the oil heavily as this will contribute to additional fouling during shooting and require more cleaning between shots.

INITIAL CLEANING PROCEDURE FOR THE LEMAT REVOLVER - MAKE SURE YOUR GUN IS UNLOADED

- 1** To clean the gun thoroughly, remove the grips (part no. 48/49) by unscrewing the screw located in the middle of same.
- 2** Remove the barrel locking stud (part no. 9A) or the barrel bracket (part no. 9B).
- 3** Unscrew the rifled barrel (part no. 8) and slide off the cylinder. Use the same cleaning procedure as above.

SPECIAL TIP: The sear adjustment screw (part no. 16) located in the right side of the frame should be used to set up the cylinder locking. Screwing this screw will slow down the release of the cylinder stop stud, unscrewing it will put forward the release of the cylinder stop stud.

INITIAL CLEANING PROCEDURE FOR THE STARR REVOLVER - MAKE SURE YOUR GUN IS UNLOADED

- 1** Draw the hammer backward in Half-Cock position (loading position).
- 2** Unscrew and remove the Take-Down Bolt.
- 3** Tilt the barrel and top frame forward away from the cylinder.

4 Pull slightly on the trigger to lower the cylinder bolt.

5 Gently pull out the cylinder.

6 Remove the grips by taking off the screws located in the backstrap.

TO ASSEMBLE THE GUN.

1 Reverse the steps in the disassembly section.

2 Make sure that the rear of the cylinder is seated in the frame first. Do not put the front of the cylinder in first or the frame will not close.

3 Gently pull the trigger to lower the cylinder stop bolt so that you will not scratch the cylinder when replacing in the frame.



CAUTION:

FIRING A REVOLVER WITH OIL, GREASE, OR ANY OTHER MATERIAL EVEN PARTIALLY OBSTRUCTING THE BORE MAY RESULT IN DAMAGE TO THE REVOLVER AND SERIOUS INJURY TO THE SHOOTER AND THOSE NEARBY. DO NOT SPRAY OR APPLY LUBRICANTS DIRECTLY ON AMMUNITION. IF THE POWDER CHARGE IS AFFECTED BY THE LUBRICANT, IT MAY NOT BE IGNITED, BUT THE ENERGY FROM THE PRIMER MAY BE ENOUGH TO PUSH THE BULLET INTO THE BORE WHERE IT MAY BECOME LODGED. FIRING A SUBSEQUENT BALL INTO THE OBSTRUCTED BORE MAY DAMAGE THE REVOLVER AND CAUSE SERIOUS INJURY OR DEATH TO THE SHOOTER AND THOSE NEARBY. USE LUBRICANTS PROPERLY.

YOU ARE RESPONSIBLE FOR THE PROPER CARE AND MAINTENANCE OF YOUR FIREARM.

STORAGE

Always unload your gun and store it and ammunition separately in a locked receptacle out of children's reach and sight, minimizing the risk that the gun and ammunition could be easily available for loading and firing.

USE YOUR REVOLVER CAREFULLY AND SAFELY



WARNING:

WE RECOMMEND TO REGISTER YOUR GUN ON
OUR INTERNET SITE:

www.pietta.it

**UNLOAD MANUALS' UPDATES FROM OUR SITE
PLEASE HAVE A LOOK AT OUR WEBSITE FOR ORIGINAL ELLI PIETTA
SPARE PARTS DISTRIBUTORS**

LEAD EXPOSURE

WARNING:

Melting lead and casting lead objects will expose you and others in the area to lead, which is known to cause birth defects, other reproductive harm and cancer.

REDUCING EXPOSURE:

Lead contamination in the air, in dust and on your skin is invisible. **Keep children and pregnant women away** during use and until cleanup is complete. Risk can be reduced-but not eliminated - with strong ventilation; washing hands immediately after use of these products before eating or smoking and careful cleaning of surfaces and floors with disposable wipes, after lead dust has had a chance to settle.

Use a lead specific cleaner with EDTA or a high-phosphate detergent (like most detergents sold for electric dishwashers) and big wipes for disposal.

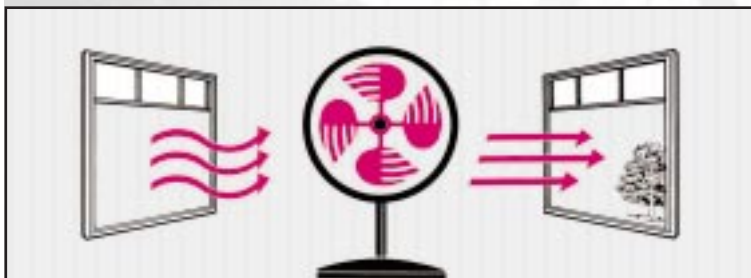

Use strong ventilation

Discharging firearms in poorly ventilated areas, cleaning firearms or handling ammunition may result in exposure to lead and other substances known to the State of California to cause birth defects, reproductive harm and other serious physical injury. Have adequate ventilation at all times. Wash hands thoroughly after exposure.

STATE WARNINGS

Certain states require by law that the manufacturer, distributor, or retail dealer provide specific-warning notices with firearms sold in that state. To comply with these laws and regulations, F.LLI Pietta includes the following warnings:

California:



WARNINGS

“CHILDREN ARE ATTRACTED TO AND CAN OPERATE FIREARMS THAT CAN CAUSE SEVERE INJURIES OR DEATH. PREVENT CHILD ACCESS BY ALWAYS KEEPING GUNS LOCKED AWAY AND UNLOADED WHEN NOT IN USE. IF YOU KEEP A LOADED FIREARM WHERE A CHILD OBTAINS AND IMPROPERLY USES IT, YOU CAN BE FINED OR SENT TO PRISON.”



ADVERTENCIA

“A LOS NIÑOS LOS ATRAEN LAS ARMAS DE FUEGO Y LAS PUEDEN HACER FUNCIONAR. ELLOS PUEDEN CAUSARSE LESIONES GRAVES Y LA MUERTE. EVITE QUE LOS NIÑOS TENGAN ACCESO A LAS ARMAS DE FUEGO GUARDÁNDOLAS SIEMPRE CON LLAVE Y DESCARGADAS CUANDO NO LAS ESTÉ UTILIZANDO. SI USTED TIENE UN ARMA DE FUEGO CARGADA EN UN LUGAR EN QUE UN NIÑO TIENE ACCESO A ELLA Y LA USA INDEBIDAMENTE, LE PUEDEN DAR UNA MULTA O ENVIARLO A LA CARCEL.”

Connecticut:

“UNLAWFUL STORAGE OF A LOADED FIREARM MAY RESULT IN IMPRISONMENT OR FINE.”

Florida:

“IT IS UNLAWFUL, AND PUNISHABLE BY IMPRISONMENT AND FINE, FOR ANY ADULT TO STORE OR LEAVE A FIREARM IN ANY PLACE WITHIN THE REACH OR EASY ACCESS OF A MINOR UNDER 18 YEARS OF AGE OR TO KNOWINGLY SELL OR OTHERWISE TRANSFER OWNERSHIP OR POSSESSION OF A FIREARM TO A MINOR OR A PERSON OF UNSOUND MIND.”

Maine:

“ENDANGERING THE WELFARE OF A CHILD IS A CRIME. IF YOU LEAVE A FIREARM AND AMMUNITION WITHIN EASY ACCESS OF A CHILD, YOU MAY BE SUBJECT TO FINE, IMPRISONMENT OR BOTH. KEEP FIREARMS AND AMMUNITION SEPARATE. KEEP FIREARMS AND AMMUNITION LOCKED UP. USE TRIGGER LOCKS.”

Maryland:

“WARNING: CHILDREN CAN OPERATE FIREARMS WHICH MAY CAUSE DEATH OR SERIOUS INJURY. IT IS A CRIME TO STORE OR LEAVE A LOADED FIREARM IN ANY LOCATION WHERE AN INDIVIDUAL KNEW OR SHOULD HAVE KNOWN THAT AN UNSUPERVISED MINOR WOULD GAIN ACCESS TO THE FIREARM. STORE YOUR FIREARM RESPONSIBLY!”

Massachusetts:

“WARNING FROM THE MASSACHUSETTS ATTORNEY GENERAL: THIS HANDGUN IS NOT EQUIPPED WITH A DEVICE THAT FULLY BLOCKS USE BY UNAUTHORIZED USERS. MORE THAN 200,000 FIREARMS LIKE THIS ONE ARE STOLEN FROM THEIR OWNERS EVERY YEAR IN THE UNITED STATES. IN ADDITION, THERE ARE MORE THAN A THOUSAND SUICIDES EACH YEAR BY YOUNGER CHILDREN AND TEENAGERS WHO GET ACCESS TO FIREARMS. HUNDREDS MORE DIE FROM ACCIDENTAL DISCHARGE. IT IS LIKELY THAT MANY MORE CHILDREN SUSTAIN SERIOUS WOUNDS, OR INFLICT SUCH WOUNDS ACCIDENTALLY ON OTHERS. IN ORDER TO LIMIT THE CHANCE OF SUCH MISUSE, IT IS IMPERATIVE THAT YOU KEEP THIS WEAPON LOCKED IN A SECURE PLACE AND TAKE OTHER STEPS NECESSARY TO LIMIT THE POSSIBILITY OF THEFT OR ACCIDENT. FAILURE TO TAKE REASONABLE PREVENTIVE STEPS MAY RESULT IN INNOCENT LIVES BEING LOST, AND IN SOME CIRCUMSTANCES MAY RESULT IN YOUR LIABILITY FOR THESE DEATHS.”

“IT IS UNLAWFUL TO STORE OR KEEP A FIREARM, RIFLE, SHOT-GUN OR MACHINE GUN IN ANY PLACE UNLESS THAT WEAPON IS EQUIPPED WITH A TAMPER-RESISTANT SAFETY DEVICE OR IS STORED OR KEPT IN A SECURELY LOCKED CONTAINER.”

New Jersey:

“IT IS A CRIMINAL OFFENSE TO LEAVE A LOADED FIREARM WITHIN EASY ACCESS OF A MINOR.”



New York City:

“THE USE OF A LOCKING DEVICE OR SAFETY LOCK IS ONLY ONE ASPECT OF RESPONSIBLE WEAPONS STORAGE. ALL WEAPONS SHOULD BE STORED UNLOADED AND LOCKED IN A LOCATION THAT IS BOTH SEPARATE FROM THEIR AMMUNITION AND INACCESSIBLE TO CHILDREN AND ANY OTHER UNAUTHORIZED PERSONS.”

North Carolina:

“IT IS UNLAWFUL TO STORE OR LEAVE A FIREARM THAT CAN BE DISCHARGED IN A MANNER THAT A REASONABLE PERSON SHOULD KNOW IS ACCESSIBLE TO A MINOR.”

Texas:

“IT IS UNLAWFUL TO STORE, TRANSPORT, OR ABANDON AN UNSECURED FIREARM IN A PLACE WHERE CHILDREN ARE LIKELY TO BE AND CAN OBTAIN ACCESS TO THE FIREARM.”

Wisconsin:

“IF YOU LEAVE A LOADED FIREARM WITHIN THE REACH OR EASY ACCESS OF A CHILD YOU MAY BE FINED OR IMPRISONED OR BOTH IF THE CHILD IMPROPERLY DISCHARGES, POSSESSES, OR EXHIBITS THE FIREARM.”

Please also check with your licensed retailer or state police for additional warnings which may be required by local law or regulation. Because such regulations are subject to change, local authorities are in the best position to advise you on such legal matters.



NOMENCLATURES

PATERSON

1 BARREL	15 CYLINDER STOP SCREW	30 TRIGGER & BOLT SPRING
2 WEDGE	16 TRIGGER SCREW	33 BACKSTAP
3 WEDGE SCREW	17 TRIGGER JACK	35 GRIP
4 SIGHT	18 TRIGGER JACK LEVER	36 PLUNGER ROD CAP
5 RECOIL SHIELD	19 TRIGGER JACK SCREW	37 PLUNGER PIN
6 CYLINDER PIN	20 TRIGGER JACK PIN	38 PLUNGER
7 FLOORPLATE	21 PLATE SCREW	39 PLUNGER ROD
8 CYLINDER HAND	22 HAMMER	40 NIPPLE CLEANER
9 CYLINDER	23 HAND & SPRING	41 PLUNGER NUT
10 NIPPLE	24 LINK	
11 TRIGGER SPRING	26 HAMMER PIN	
12 FRAME	27 RECOIL SHIELD SCREW	
13 TRIGGER	28 MAINSPRING	
14 CYLINDER STOP	29 HAND SPRING	

ALWAYS STATE TYPE AND CALIBER OF GUN WHEN ORDERING SPARE PARTS.

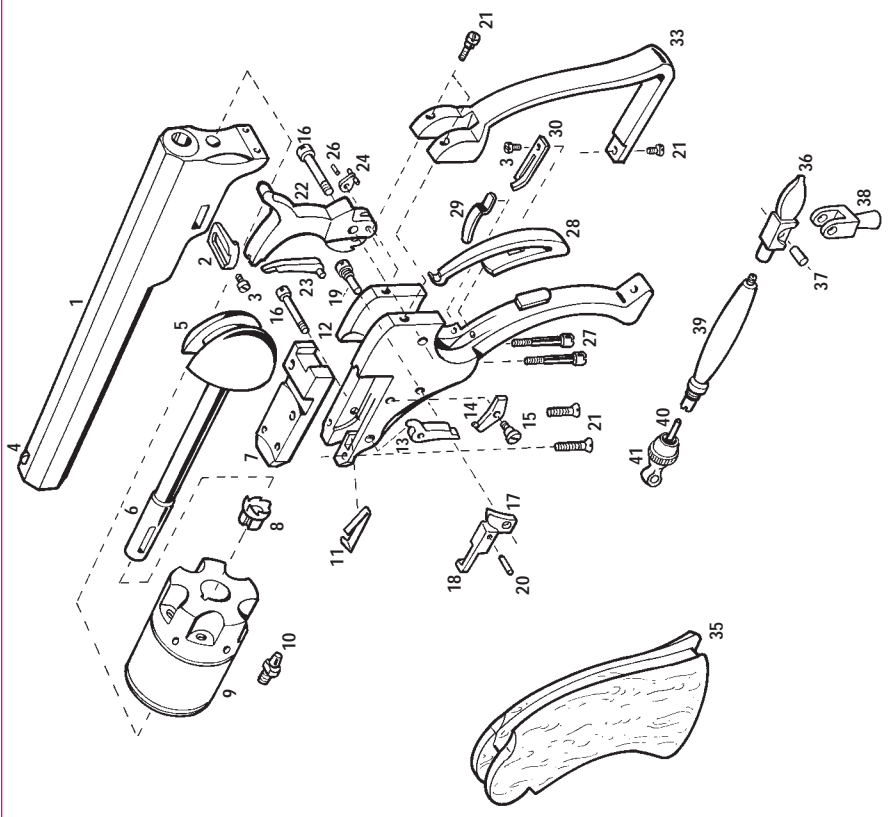

1851 NAVY

1 BARREL	15 CYLINDER	31 MAINSPRING
2 FRONT SIGHT	16 NIPPLE	32 MAINSPRING SCREW
3 BARREL CATCH	17 HAND & SPRING	33 GRIPS
4 LOADING LEVER LATCH	18 HAMMER	34 BACKSTRAP
5 LOADING LEVER LATCH SPRING	19 HAMMER SCREW	37 BARREL LOCKING PIN
6 LOADING LEVER LATCH PIN	20 ROLLER	38 RING SCREW
7 LOADING LEVER	21 ROLLER PIN	39 RING
8 PLUNGER	22 BOLT	41 CYLINDER LOCKING PIN
9 PLUNGER SCREW	23 TRIGGER BOLT SCREW	73 CYLINDER SAFETY PIN
10 LOADING LEVER SCREW	24 TRIGGER	
11 WEDGE +57 +58	26 TRIGGER & BOLT SPRING	
12 WEDGE SCREW	28 TRIGGER GUARD	
13 CYLINDER PIN	29 REAR TRIGGER GUARD SCREW	
14 FRAME	30 FRONT TRIGGER GUARD SCREW	

ALWAYS STATE TYPE AND CALIBER OF GUN WHEN ORDERING SPARE PARTS.

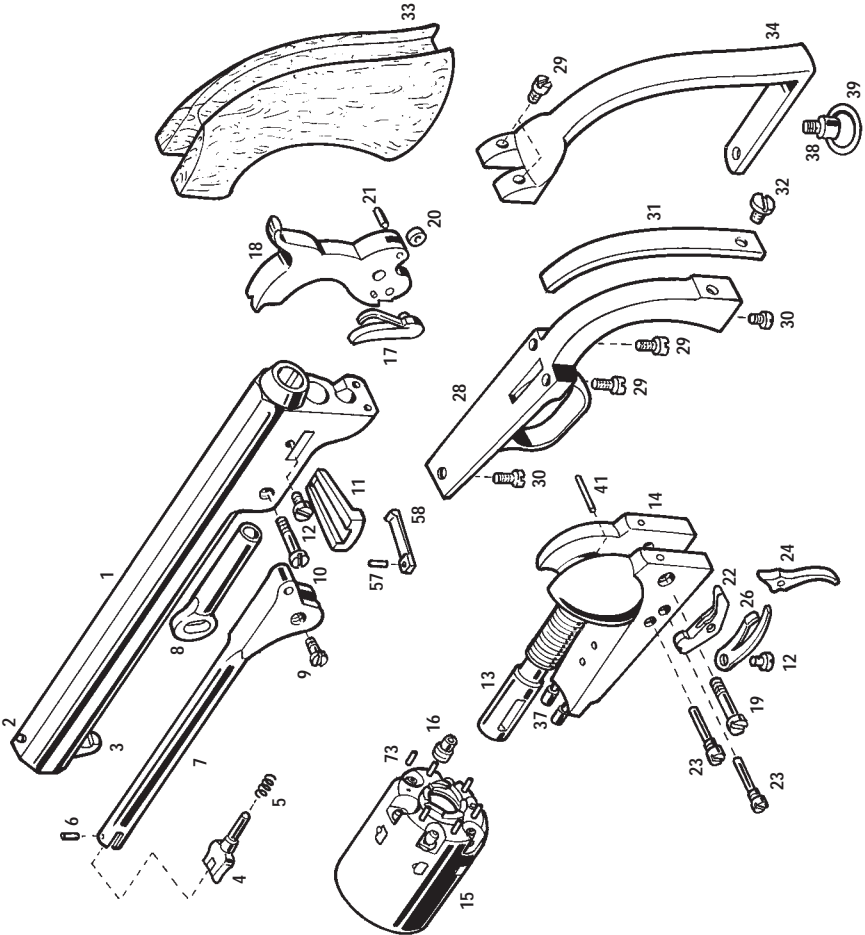

1860 ARMY

1 SIGHT	15 CYLINDER PIN	30 REAR TRIGGER GUARD SCREW
2 BARREL	16 STOCK RETAINER SCREW	31 BACKSTRAP
3 BARREL CATCH	17 FRAME	34 MAINSPRING
4 LOADING LEVER	18 HAMMER	35 MAINSPRING SCREW
5 LOADING LEVER LATCH	19 HAND & SPRING	36 GRIP
6 LOADING LEVER LATCH SPRING	20 ROLLER	37 BARREL LOCKING PIN
7 LOADING LEVER LATCH PIN	21 ROLLER PIN	38 LOWER BACKSTRAP SCREW
8 PLUNGER	22 HAMMER SCREW	39 CYLINDER LOCKING PIN
9 PLUNGER SCREW	23 BOLT & TRIGGER SCREW	
10 WEDGE	24 BOLT	
11 WEDGE SCREW	25 TRIGGER	
12 CYLINDER	26 TRIGGER & BOLT SPRING	
13 NIPPLE	28 TRIGGER GUARD	
14 CYLINDER SAFETY PIN	29 FRONT TRIGGER GUARD SCREW	

ALWAYS STATE TYPE AND CALIBER OF GUN WHEN ORDERING SPARE PARTS.

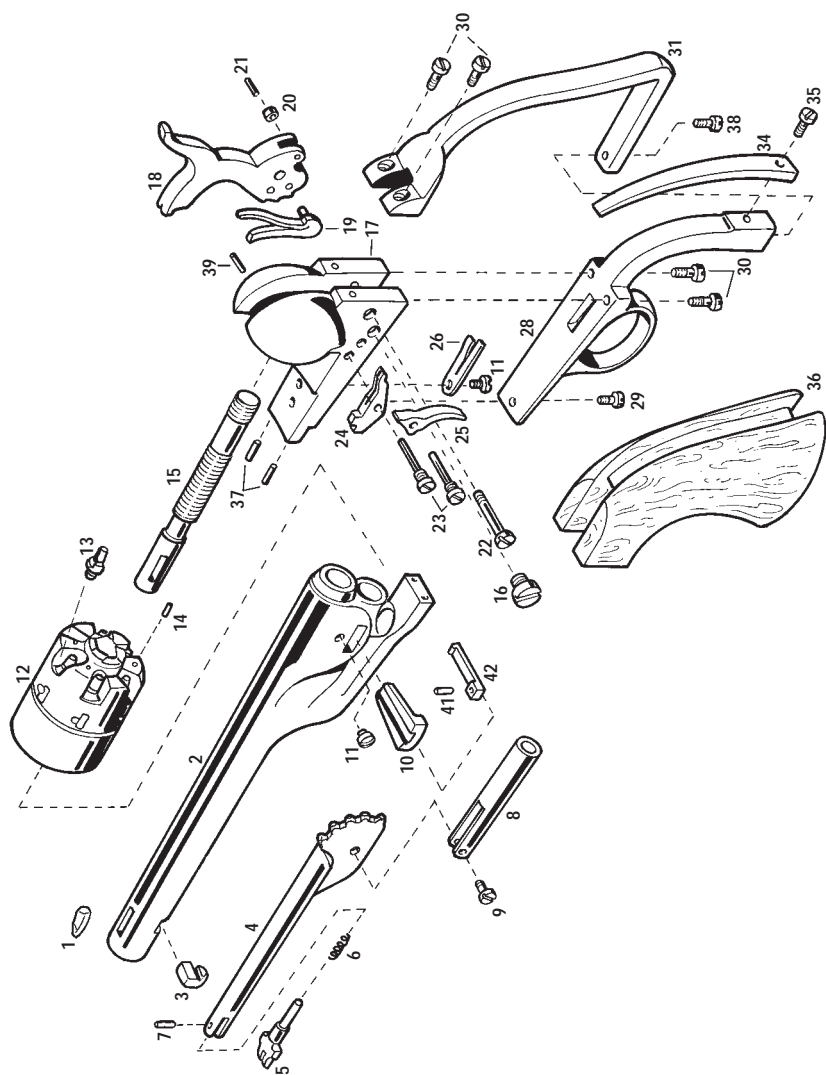

1858 NEW MODEL ARMY

1	FRAME	15	RIGHT GRIP	29	TRIGGER & BOLT SCREW	49	REAR SIGHT PLATE
2	BARREL	16	GRIP NUT	30	HAMMER SCREW	50	FRONT SIGHT FIXING SCREW
3	CYLINDER	17	HAMMER	31	GRIP SCREW	53	ADJUSTMENT SCREW
4	LOADING LEVER	18	HAND	32	PLUNGER PIN		
5	PLUNGER	19	HAND SCREW	33	TRIGGER & BOLT SPRING SCREW		
6	CYLINDER PIN	20	ROLLER PIN	34	TRIGGER GUARD SCREW		
7	TRIGGER GUARD	21	ROLLER	35	MAIN SPRING SCREW		
8	TRIGGER & BOLT SPRING	22	LATCH PIN	36	GRIP PIN		
9	BOLT	23	LATCH SPRING	37	SIGHT		
10	TRIGGER	24	LOADING LEVER LATCH	40	FRONT TARGET SIGHT		
11	NIPPLE	25	BARREL CATCH	41	REAR SIGHT TARGET +43 +49		
12	GRIP NUT	26	LINK	42	SHORT REAR SIGHT FIXING SCREW		
13	LEFT GRIP	27	LINK PIN	43	ADJUSTMENT SCREW		
14	MAIN SPRING	28	LOADING LEVER SCREW	48	LONG REAR SIGHT FIXING SCREW		

ALWAYS STATE TYPE AND CALIBER OF GUN WHEN ORDERING SPARE PARTS.

1858 NEW MODEL ARMY

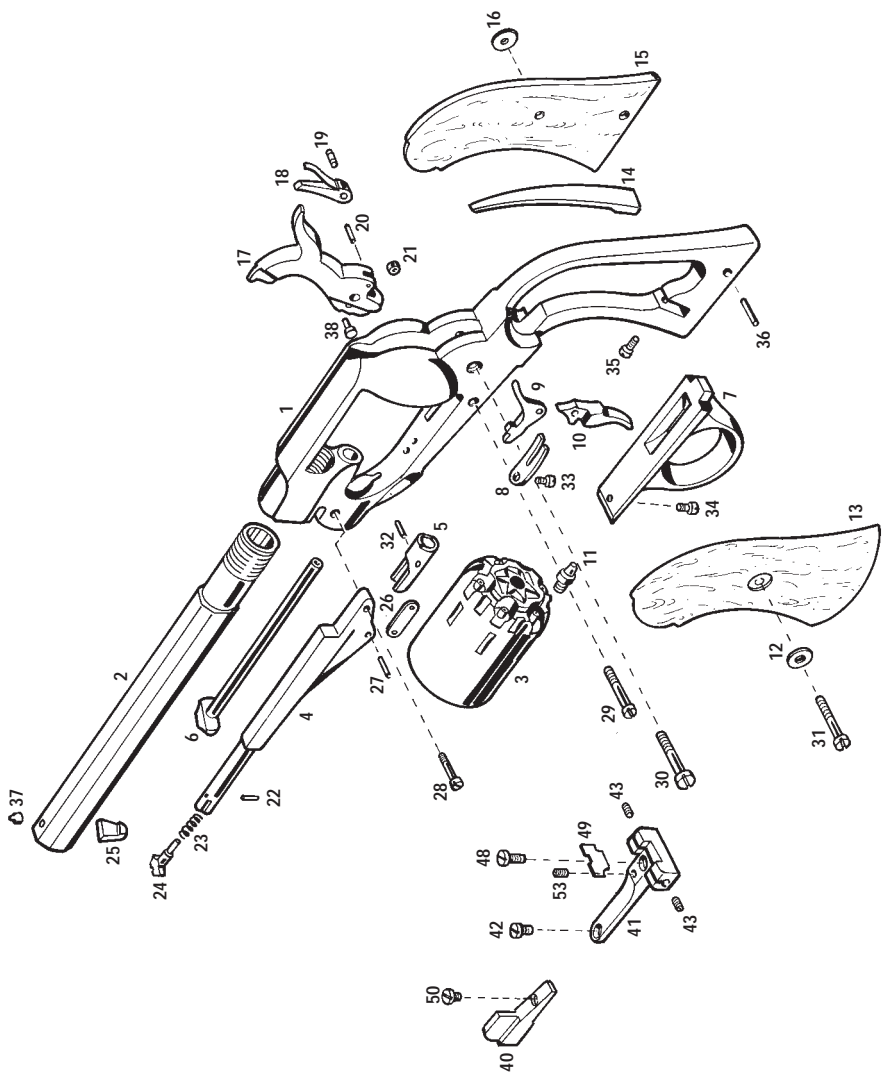

1863 NEW MODEL POCKET .31 cal

1 FRAME	17 TRIGGER	31 LOADING LEVER SCREW
2 CYLINDER	18 BOLT	32-33 RIGHT & LEFT GRIP
3 NIPPLE	19 TRIGGER SCREW	34 GRIP NUT
4 CYLINDER PIN	20 TRIGGER & BOLT SPRING	35 THREADED GRIP NUT
5 BARREL	21 TRIGGER & BOLT SPRING SCREW	36 GRIP PIN
6 SIGHT	22 TRIGGERGUARD	37 GRIP SCREW
7 BARREL CATCH	23 TRIGGERGUARD SCREW	
8 HAMMER	24 LOADING LEVER	
10 ROLLER	25 LATCH	
11 ROLLER PIN	26 LATCH SPRING	
12 HAMMER SCREW	27 LATCH PIN	
13 HAND	28 PLUNGER	
15 HAND SCREW	29 LINK	
16 MAINSPRING	30 LINK PIN	

ALWAYS STATE TYPE AND CALIBER OF GUN WHEN ORDERING SPARE PARTS.

**1863
NEW
MODEL
POCKET**

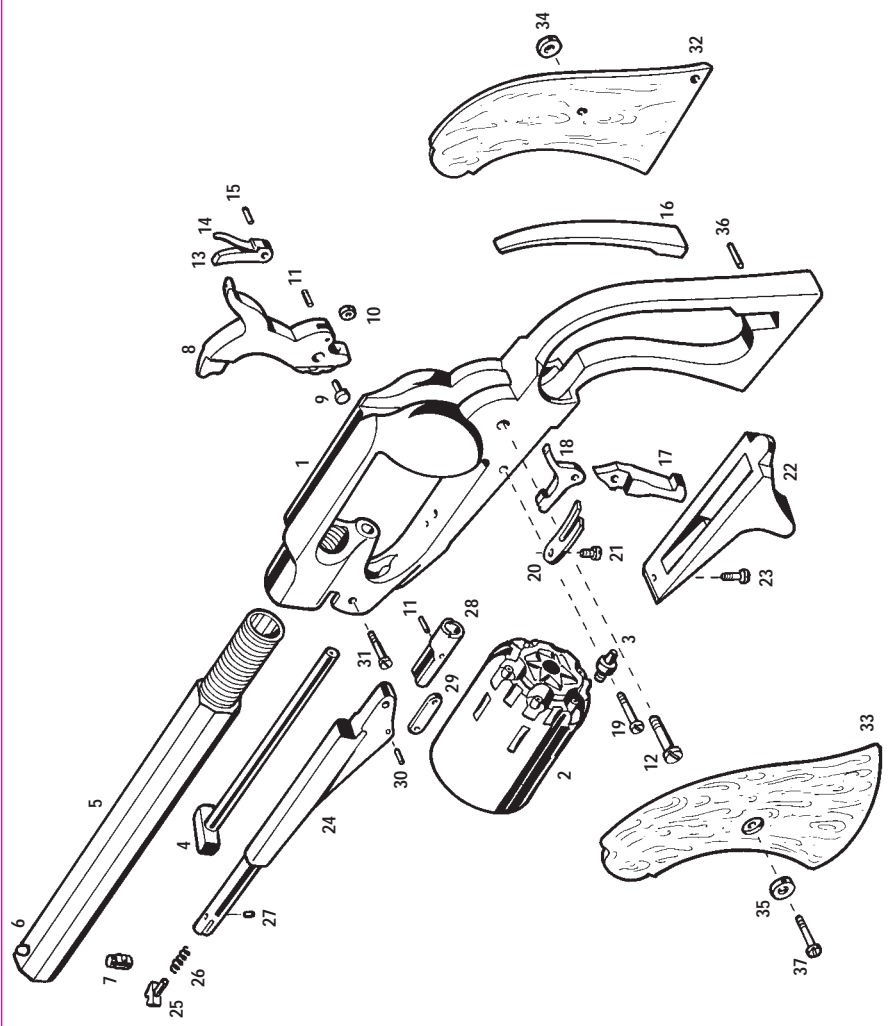

1862 SPILLER & BURR

1 FRAME	15 LATCH	30 HAND
2 BARREL	16 LOADING LEVER SCREW	31 HAND SCREW
3 SIGHT	17 LINK	32 GRIP SCREW
4 BARREL CATCH	18 LINK PIN	33-34 RIGHT & LEFT GRIP
5 CYLINDER PIN	19 PLUNGER	35 MAINSPRING
6 CYLINDER PIN LOCKING PIN	20 TRIGGER & BOLT SPRING	36 TRIGGERGUARD
7 CYLINDER PIN LOCKING PIN SCREW	21 TRIGGER & BOLT SPRING SCREW	37 TRIGGERGUARD SCREW
8 CYLINDER PIN LOCKING PIN ROLLER	22 CYLINDER STOP (BOLT)	
9 CYLINDER	23 CYLINDER STOP SCREW	
10 NIPPLE	24 TRIGGER	
11 LOADING LEVER / PLUNGER SCREW	26 HAMMER	
12 LOADING LEVER	27 HAMMER SCREW	
13 LATCH PIN	28 ROLLER PIN	
14 LATCH SPRING	29 ROLLER	

ALWAYS STATE TYPE AND CALIBER OF GUN WHEN ORDERING SPARE PARTS.

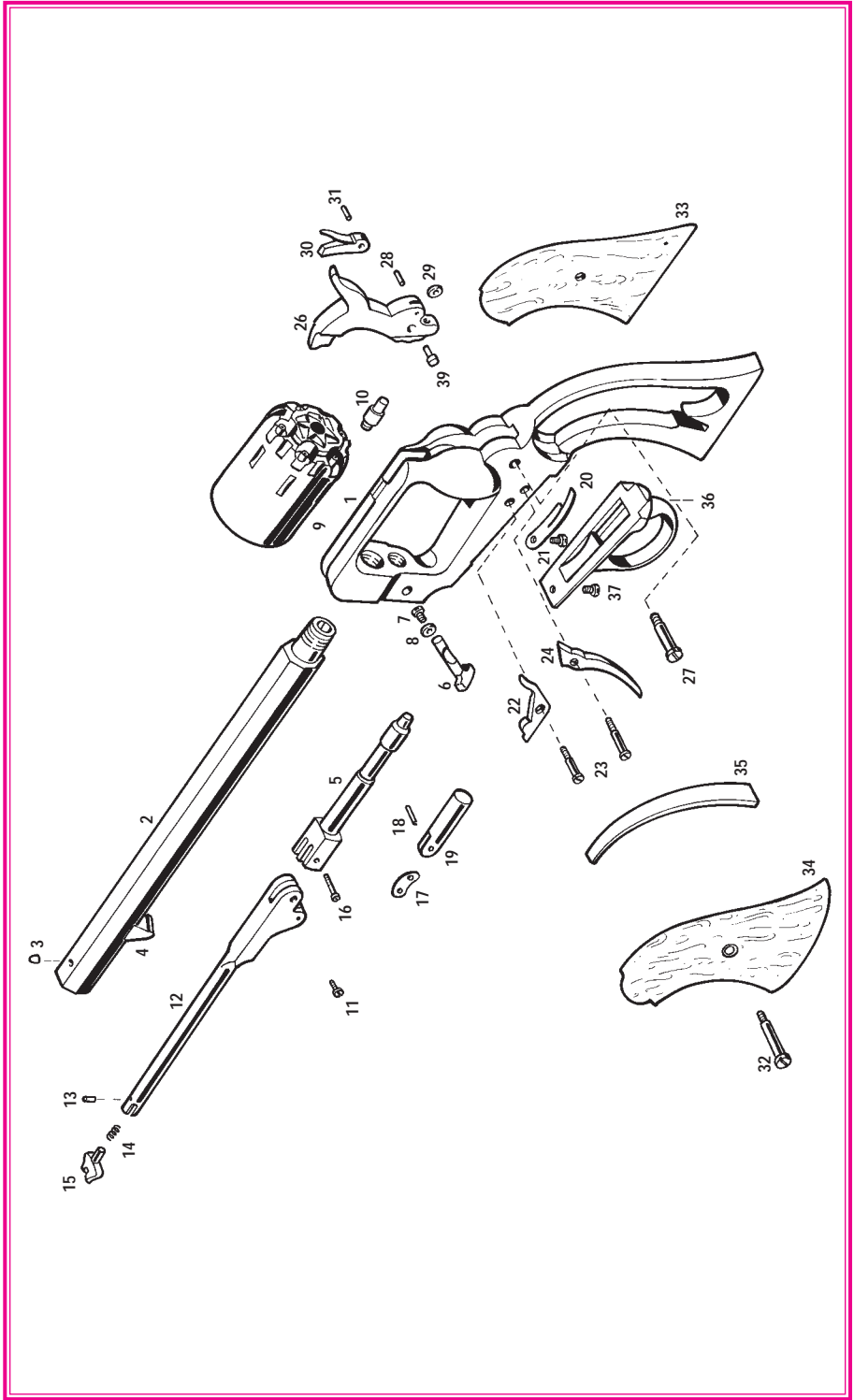

LE MAT

1 SHOT BARREL RAMROD	13 NIPPLE	27 TRIGGER PIN	41 HAND BRACKET
2 LOADING LEVER TUBE	14 SHOT BARREL .20 GA.	28 TRIGGERGUARD	42 HAND BRACKET SCREW
3 LOADING LEVER	15 BREECH PLUG	29 FRONT TRIGGERGUARD SCREW	43 MAINSPRING
4 PLUNGER SCREW	16 TENSION SPRING ADJ. SCREW	30 REAR TRIGGERGUARD SCREW	44 MAINSPRING SCREW
5 PLUNGER	17 SIDE PLATE NUT	31 HAMMER NOSE	45 GRIP SCREW
6 LOADING LEVER SCREW	18 HAMMER SCREW	32 HAMMER	46 RIGHT GRIP LOCKING NUT
7 FRONT SIGHT	19 CYLINDER STOP	33 HAMMER NOSE SPRING SCREW	47 LEFT GRIP NUT
8 BARREL	20 CYLINDER STOP RETURN SPRING	34 HAMMER NOSE SPRING	48-49 LEFT/RIGHT GRIP
9A TAKEDOWN PIN (ARMY/NAVY)	21 CYLINDER STOP RETAINING NUT	35 HAMMER NOSE SCREW	50 LOADING LEVER RETAINING SPRING SCREW
9B TAKEDOWN LEVER (CAVALRY)	22 TRIGGER SPRING	36 CYLINDER STOP TENSION SPRING	51 LOADING LEVER RETAINING SPRING
9C TAKEDOWN LEVER SPRING	23 FRAME	37 CYL. STOP TENSION SPRING SCREW	52 LANYARD BASE
10 TAKEDOWN PIN SPRING	24 SIDE PLATE	38 MAINSPRING RETAINER	53 LANYARD RING
11 TAKEDOWN PIN SPRING SCREW	25 TAKEDOWN LEVER PIN	39 MAINSPRING RETAINER PIN	54 CYLINDER STOP SCREW
12 CYLINDER	26 TRIGGER	40 HAND & SPRING	55 HAMMER NOSE PIN

ALWAYS STATE TYPE AND CALIBER OF GUN WHEN ORDERING SPARE PARTS.

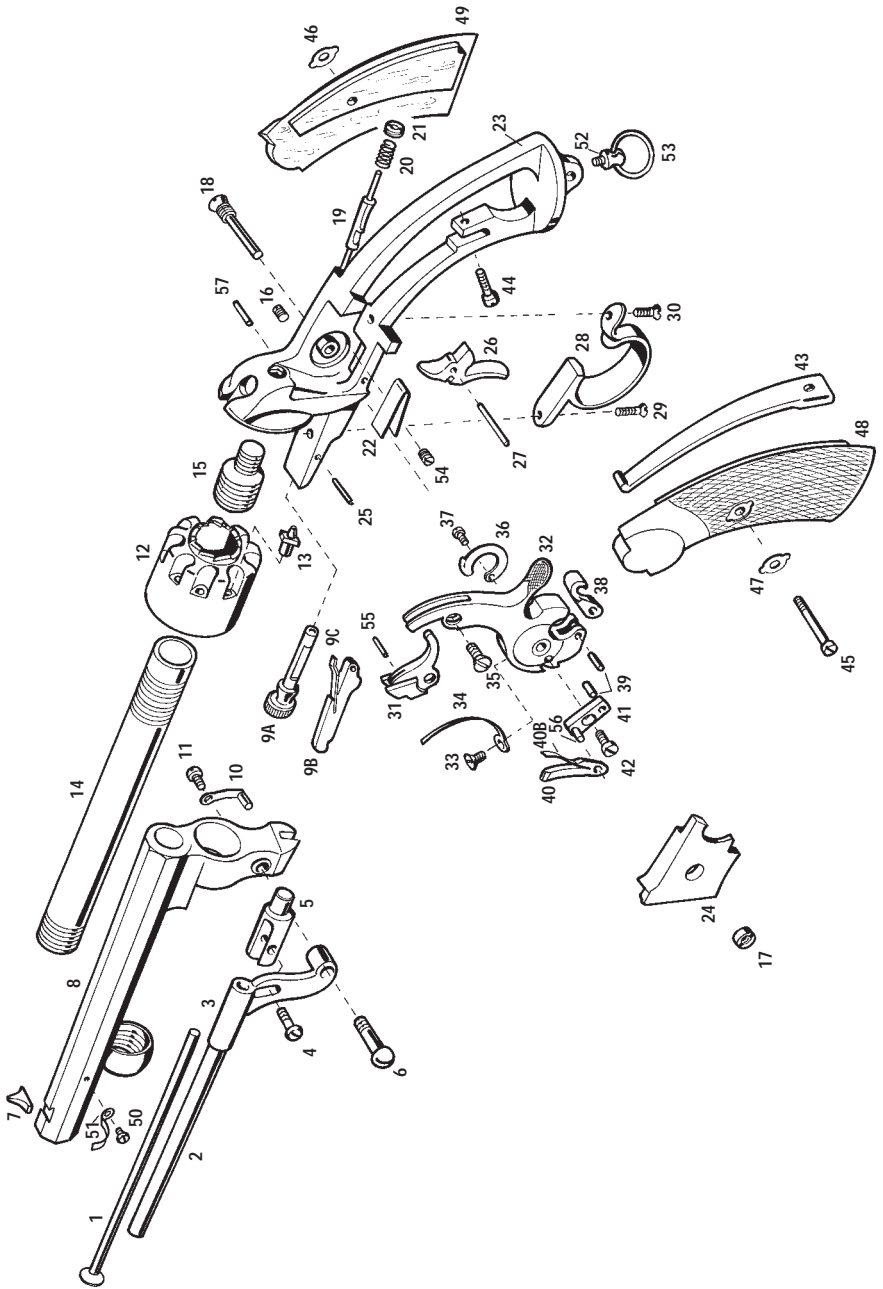

1873 SINGLE ACTION

1 FRAME	15 FRONT SIGHT	29 HAND SPRING	49 BOLT RECALL SPRING
2 BASE PIN	16 EJECTOR HOUSING	30 HAMMER SCREW	50 HRING PIN PROTECTOR BUSHING
3 BASE PIN LATCH	17 EJECTOR HOUSING SCREW	31 TRIGGER	
4 BASE PIN LATCH NUT	18 EJECTOR HOUSING SCREW BUSHING	32 BOLT	
5 BASE PIN LATCH SPRING	19 EJECTOR HEAD	33 TRIGGER & BOLT SPRING	
6 BASE PIN BUSHING	20 EJECTOR ROD	34 TRIGGER SCREW	
7 CYLINDER	21 EJECTOR SPRING	35 BOLT SCREW	
8 TRIGGER GUARD	22 HAMMER	36 TRIGGER SPRING SCREW	
9 BACKSTRAP	23 HRING PIN RIVET	37 MAINSPRING	
10 GATE	24 HRING PIN	38 MAINSPRING SCREW	
11 GATE CATCH	25 HAMMER ROLLER PIN	39 BACKSTRAP/TRIGGERGUARD REAR SCREW	
12 GATE SPRING	26 HAMMER ROLLER	41 BACKSTRAP/TRIGGERGUARD FRONT SCREW	
13 GATE CATCH SCREW	27 HAND PIN	42 GRP	
14 BARREL	28 HAND	48 BOLT RECALL SPRING GUIDE	

ALWAYS STATE TYPE AND CALIBER OF GUN WHEN ORDERING SPARE PARTS.

1873 SINGLE ACTION

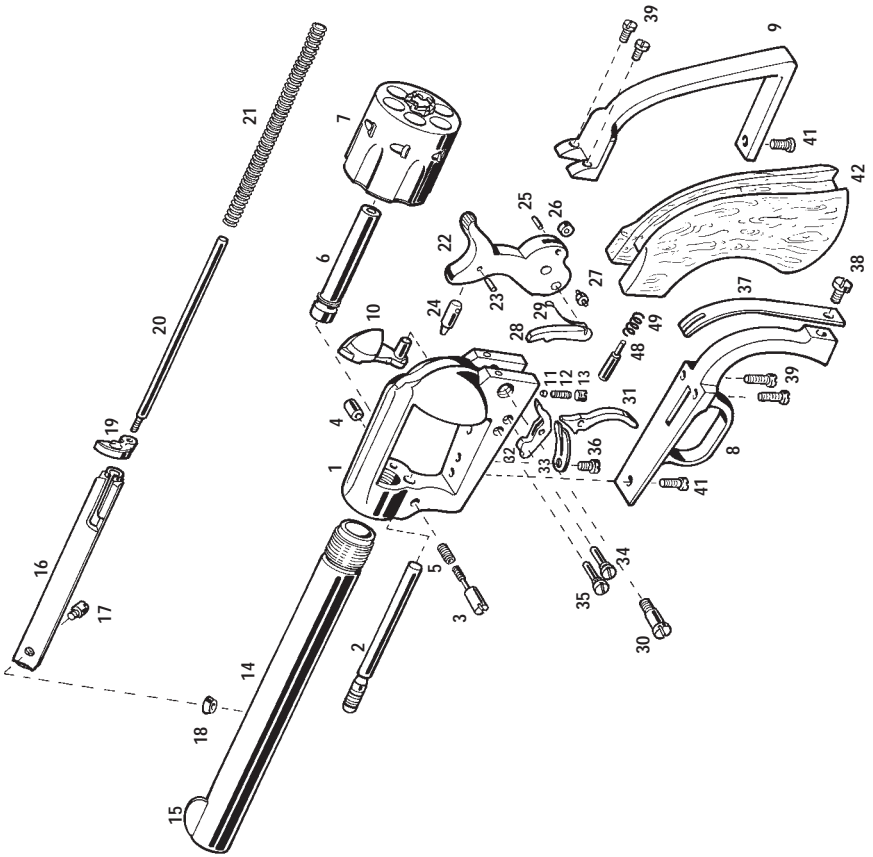

1863 STARR SINGLE ACTION

1	TOP FRAME		
19	MAINSRING CONNECTING ROD PIN		37 MAINSRING LOCKING SCREW
2	BOTTOM FRAME		38 CYLINDER HAND LOCKING SCREW
3	CYLINDER		39 HAMMER/FRAMES LOCKING SCREW
4	CYLINDER HAND LOCKING PIN		40 GRIP LOCKING SCREW
5	CYLINDER HAND		41 GRIP SCREW
6	TRIGGERGUARD		42 NIPPLE
7	TRIGGER		43 BOLT
8	TRIGGER LOCKING PIN		44 LOADING LEVER SCREW
10	BACKSTRAP		45 TRIGGER & BOLT SPRING
11	GRIPS		
12	HAMMER		
13	HAND & SPRING		
14	HAND SPRING		
18	MAINSRING CONNECTING ROD		
		20 MAINSPRING	
		25 BARREL	
		26 SIGHT	
		27 BARREL CATCH	
		28 LOADING LEVER	
		29 LOADING LEVER LATCH	
		30 LOADING LEVER LATCH SPRING	
		31 LOADING LEVER LATCH PIN	
		32 FLUNGER	
		33 TRIGGER SPRING LOCKING SCREW	
		34 TRIGGERGUARD SCREW	
		35 FLUNGER SCREW	
		36 TAKE-DOWN BOLT	

ALWAYS STATE TYPE AND CALIBER OF GUN WHEN ORDERING SPARE PARTS.

**1863
STARR
SINGLE
ACTION**

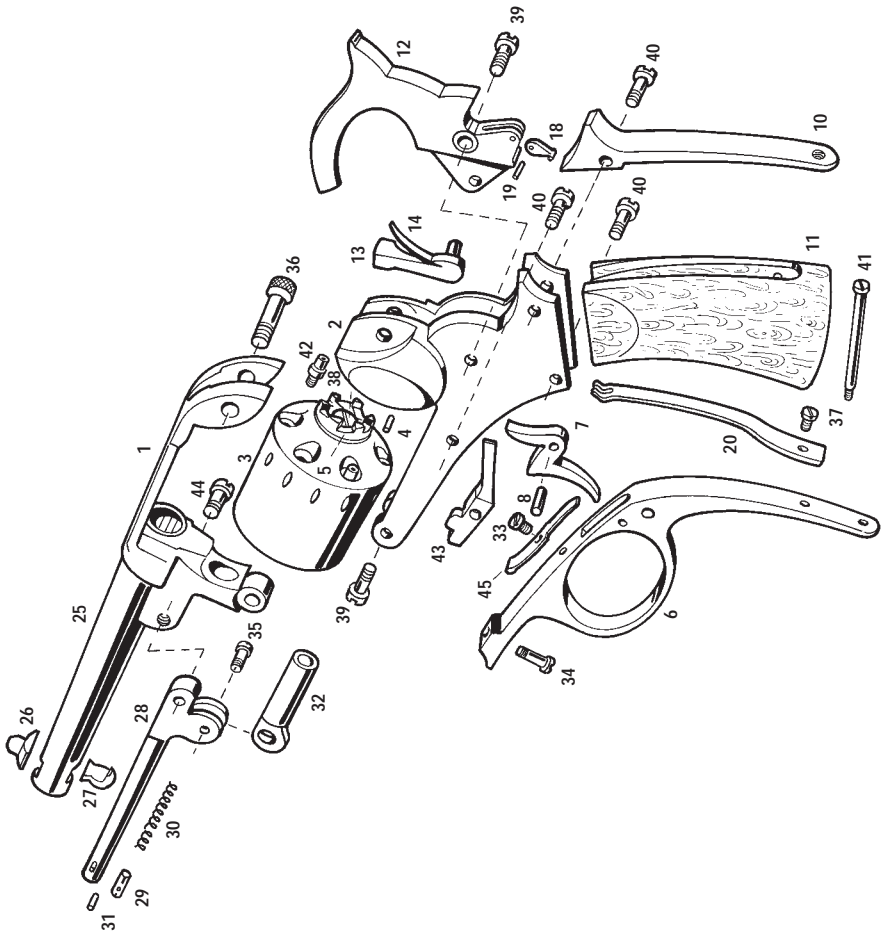

1858 STARR DOUBLE ACTION

1 TOP FRAME	15 HAMMER PIVOTING LEVER	29 LOADING LEVER LATCH	43 HAND & SPRING PIN
2 BOTTOM FRAME	16 HAMMER PIVOTING LEVER PIN	30 LOADING LEVER LATCH SPRING	44 LOADING LEVER SCREW
3 CYLINDER	17 HAMMER PIVOTING LEVER SPRING	31 LOADING LEVER LATCH PIN	
4 CYLINDER HAND LOCKING PIN	18 MAINSPRING CONNECTING ROD	32 PLUNGER	
5 CYLINDER HAND	19 MAINSPRING CONNECTING ROD PIN	33 TRIGGER SPRING LOCKING SCREW	
6 TRIGGERGUARD	20 MAINSPRING	34 TRIGGERGUARD SCREW	
7 SECONDARY TRIGGER	21 MAIN TRIGGER	35 PLUNGER SCREW	
8 TRIGGER LOCKING PIN	22 SELECTOR ACTION SPRING	36 TAKE-DOWN BOLT	
9 SECONDARY TRIGGER SPRING	23 SELECTOR ACTION SPRING SCREW	37 MAINSPRING LOCKING SCREW	
10 BACKSTRAP	24 MAIN TRIGGER SPRING	38 CYLINDER HAND LOCKING SCREW	
11 GRIP	25 BARREL	39 HAMMER TO FRAMES LOCKING SCREW	
12 HAMMER	26 SIGHT	40 GRIP LOCKING SCREW	
13 HAND & SPRING	27 BARREL CATCH	41 GRIP SCREW	
14 HAND SPRING	28 LOADING LEVER	42 NETTLE	

ALWAYS STATE TYPE AND CALIBER OF GUN WHEN ORDERING SPARE PARTS.

1858 STARR DOUBLE ACTION

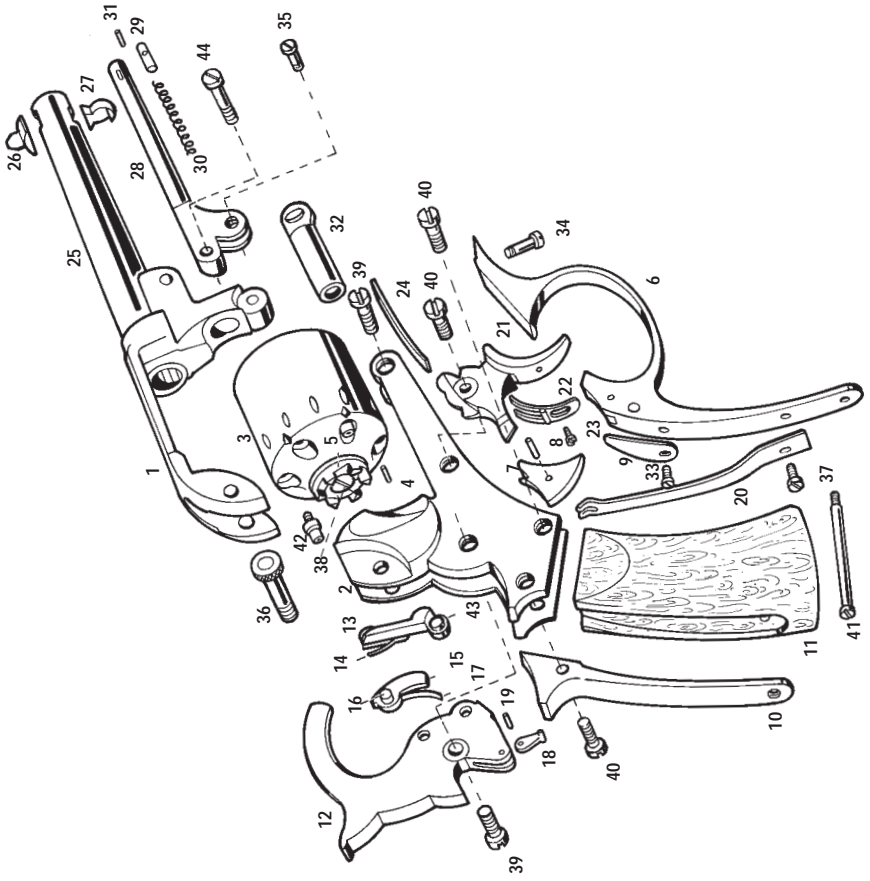

SMITH CARBINE .50 cal.

1	FRONT SIGHT BLADE	15	SWIVEL	29	RECEIVER SIDE PLATE	43	LONG BUTSTOCK SCREW
2	FRONT SIGHT BASE	16	FOREND	30	FRAME	44	BUTT SWIVEL BASE
3	BARREL	17	FOREND WASHER	31	TRIGGER SCREW	45	BUTPLATE
4	REAR SIGHT SCREW	18	FOREND SCREW	32	SPRING ACTION LOCK ACTUATOR	46	REARSIGHT PLATE PIN
5	REAR SIGHT SPRING	19	BRECH PLUG	33	FRONT TRIGGERGUARD SCREW	47	SADDLE RING
6	REAR SIGHT BASE	20	ACTION TO BARREL HINGE SCREW	34	TRIGGER	48	SADDLE RING RETAINER
7	REAR SIGHT ELEVATOR	21	NIPPLE	35	TRIGGERGUARD	49	SADDLE RING RETAINER SCREW
8	REAR SIGHT PLATE	22	NIPPLE CLEANOUT SCREW	36	REAR TRIGGERGUARD SCREW	50	FRAME/PLATE PIN
9	REAR SIGHT PIN	23	TRIGGER SPRING PIN	37	TRIGGERGUARD SCREW	51	FRAME/STOCK PIN
10	TOP STRAP SCREW	24	TRIGGER SPRING	38	STRIPP	52	FRAME BAND RING
11	TOP STRAP	25	TUMBLER	39	MAINSRING	54	SPRING ACTION LOCK ACTUATOR SCREW
12	FRONT BAND PIN	26	HAMMER	40	MAINSRING SCREW		
13	BARREL BAND	27	HAMMER SCREW	41	STOCK		
14	BARREL BAND SCREW	28	SIDEPLATE SCREW	42	BUTPLATE SCREW		

ALWAYS STATE TYPE AND CALIBER OF GUN WHEN ORDERING SPARE PARTS.

